

HID Aero™ X1100 Intelligent Controller

Up to 4 Readers, 7 Inputs, 4 Outputs

Supplied parts

- HID Aero X1100 Intelligent Controller (1)
- Installation guide (1)
- Mounting screws (4) 0.138" × 1" (3.5 mm × 25 mm)
- Casing screws (4) 0.118" × 0.75" (3 mm × 20 mm)

Recommended parts (not supplied)

- Certified DC power supply
- Drill with various bits for mounting hardware
- For DIN rail mounting: Brackets (2) - Phoenix Contact, USA 10 Series Rail Adapter, part number 1201578. Screws (4) - Self tapping, countersunk, 3.0 mm × 10 mm (or 3.0 mm × 8 mm)

CABLE REQUIREMENTS (NOT SUPPLIED)	
Host-Ethernet	CAT-5, 328 ft (100 m)
Readers-OSDP	4 conductor twisted pair over-all shield, Belden 3107A or equivalent. 2000 ft (610 m) maximum. Utilize one pair for data and one pair for power
Readers-Wiegand / C&D	4-conductor, 18 AWG, shielded, 500 ft (150 m) maximum
IO Modules*	One twisted pair, shielded. 120Ω impedance, 24 AWG, 4,000 ft (1,219 m) maximum
Alarm Inputs	One twisted pair, 30Ω maximum, typically 22 AWG, 1000 ft (304.8 m)
Power and Relays	2-conductor shielded 18 to 16 AWG, 500 ft (150 m)

*VertX wire specifications are compatible with X1100. Utilize existing VertX V100, V200 and V300 RS-485 wiring when attaching to X1100.

X1100 Overview

The X1100 performs intelligent access control operations, input monitoring and output control for up to: 64 readers, 64 doors, 615 inputs, 388 outputs.

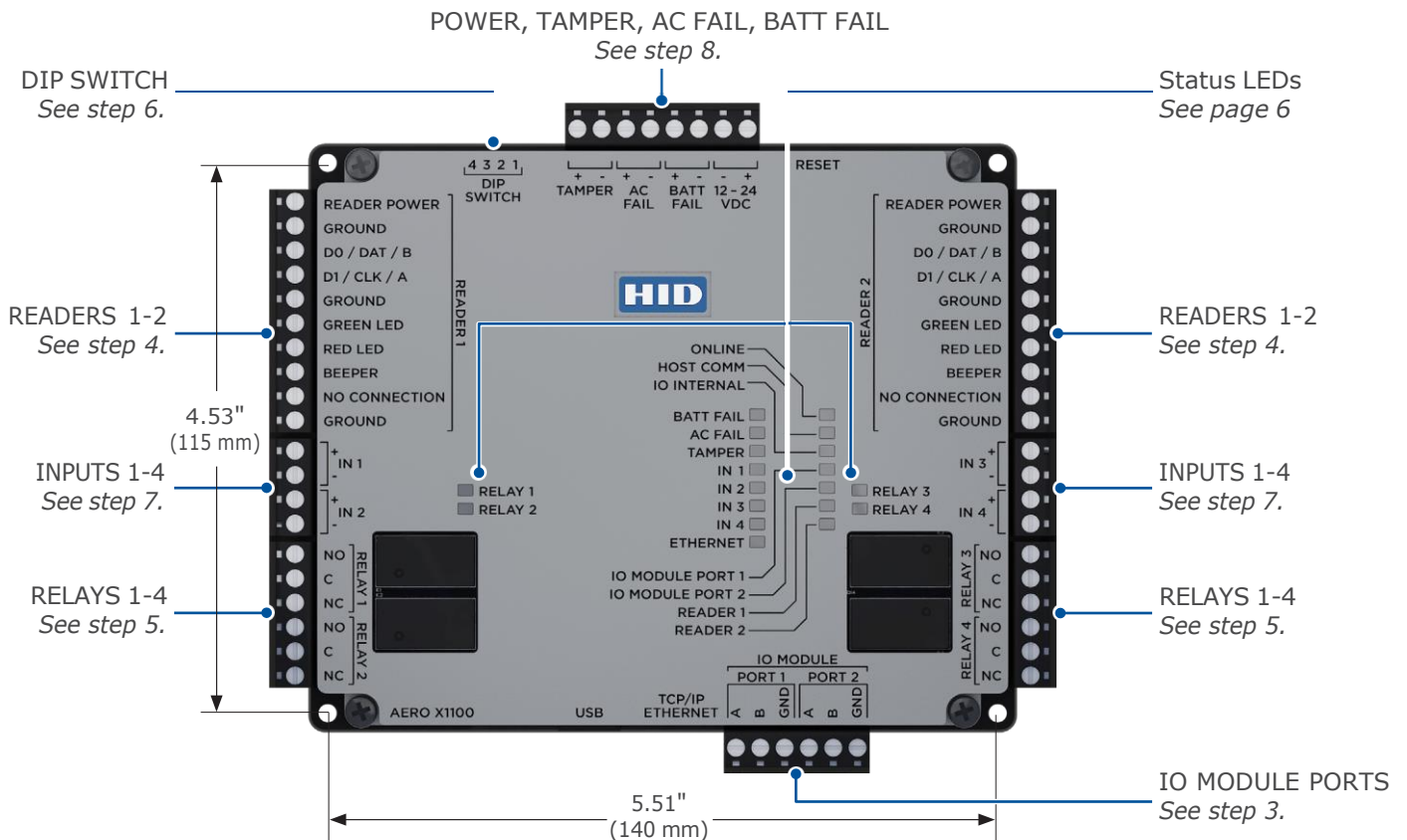

1. Setting the jumpers

1. If attached, unscrew the four corner casing screws.
2. Remove the X1100 casing to access the battery jumper and the end of line termination jumpers.
3. Set the battery jumper J4 to ON.
4. Set IO Module Port 1 and 2 end of line termination jumpers J5 and J9 to IN, only if the X1100 will be the end of communication bus.
5. Replace the casing and secure with the supplied four corner casing screws.

Note: The static RAM and the real time clock are backed up by a lithium battery when input power is removed. This battery should be replaced annually.

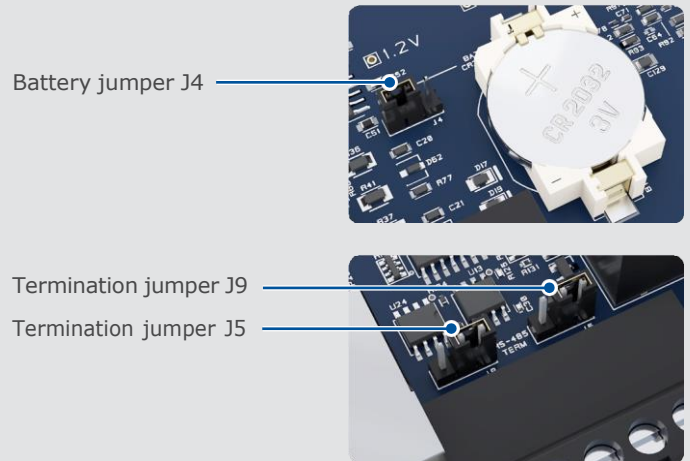

2. Mounting the X1100



ATTENTION

Observe precautions for handling ELECTROSTATIC SENSITIVE DEVICES

- Always mount the controllers and interface panels in a secure area.
- Mount using the supplied screws 0.138" × 1" (3.5 mm × 25 mm).
- Alternatively mount on a DIN rail using compatible DIN rail mounting brackets and screws. See *Recommended parts*.

Note: The side terminal connectors must be removed to fit the mounting brackets.

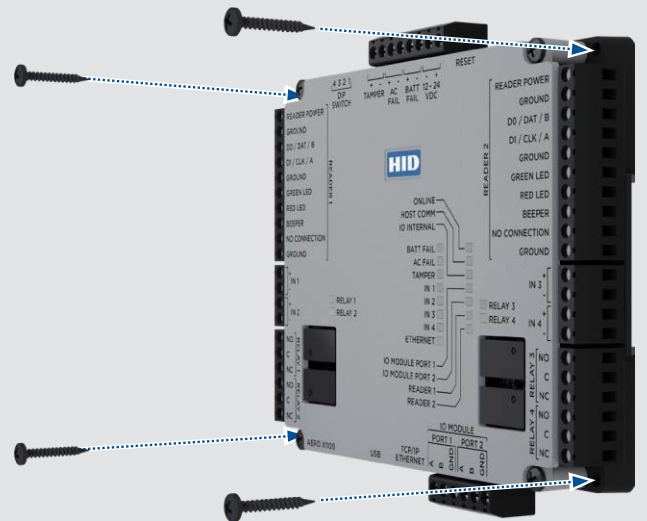

3. Communication wiring

Connect the X1100 to additional IO modules using 2-wire RS-485 IO Module ports 1 and 2. Use 1-twisted pair, shielded cable, 120Ω impedance, 24 AWG, 4,000 ft. (1,219 m) maximum.

Each port can support up to 32 (Aero) or 16 (VertX) IO modules.

Note: Install RS-485 termination jumpers on the interface boards at each end of the communication bus only (see step 1 above). Failure to do so will compromise the proper operation of the communication channel.

Network connection

The X1100 controller communicates to the host via the on-board Ethernet 10-BaseT/100Base-TX port.

IO MODULE PORT 1 or IO MODULE PORT 2

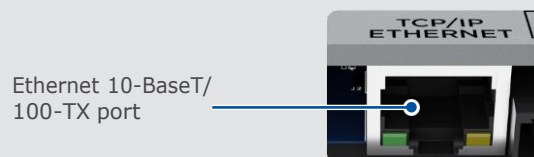
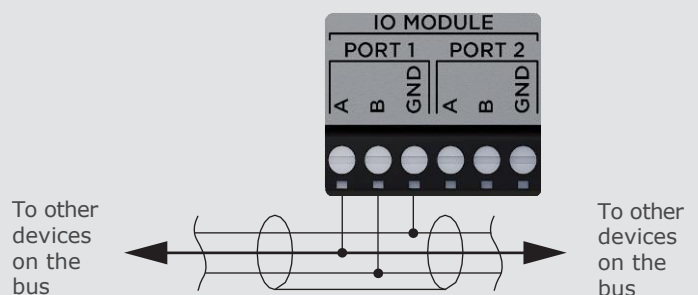

4. Connecting readers

- OSDP (RS-485) signaling requires two 2-conductor cables. One cable for power (18 AWG) and one cable for communication (24 AWG, shielded, twisted pair).
- Wiegand or Clock/Data (TTL) signaling requires a 4-conductor cable (18 AWG, shielded) with additional optional conductors for LED and beeper control.

CAUTION

Readers that require different voltage or have high current requirements should be powered separately. Refer to the reader manufacture specifications for cabling requirements.

Note: For OSDP cable lengths greater than 200 ft (61 m) or EMF interference, install 120Ω +/- 2Ω resistor across RS-485 termination ends.

Note: Data 0 and Data 1 wires for Wiegand may be reused for OSDP. However, standard Wiegand cable may not meet RS-485 twisted pair recommendations. The reuse of cable works best on shorter cable lengths at lower data rates.

HID Signo™ reader (OSDP installation)

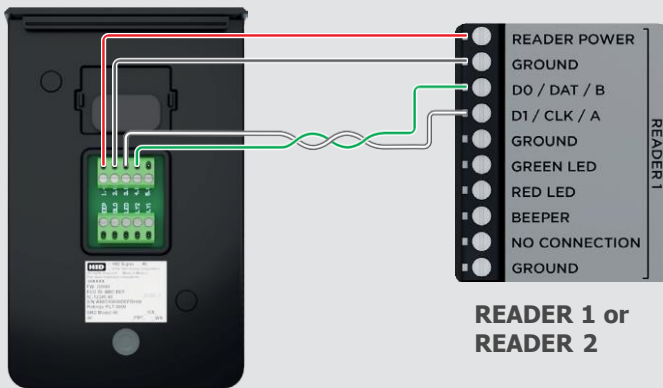

HID Signo reader (Wiegand or Clock/Data installation)

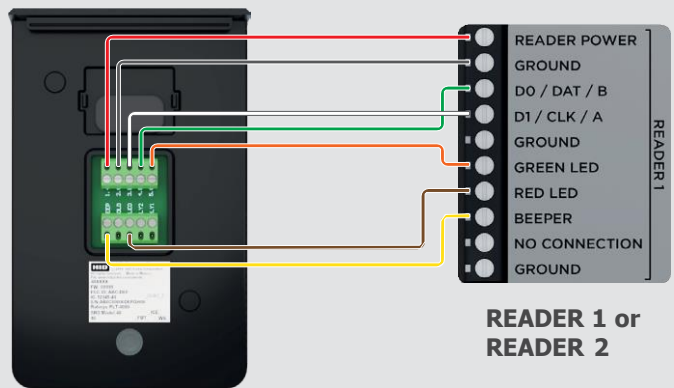

Typical reader (OSDP installation)

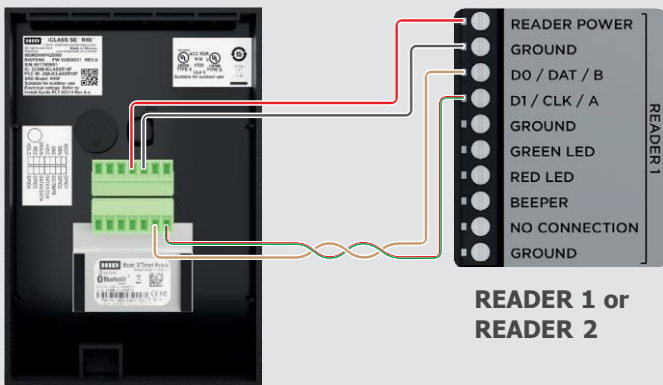

Typical reader (Wiegand or Clock/Data installation)

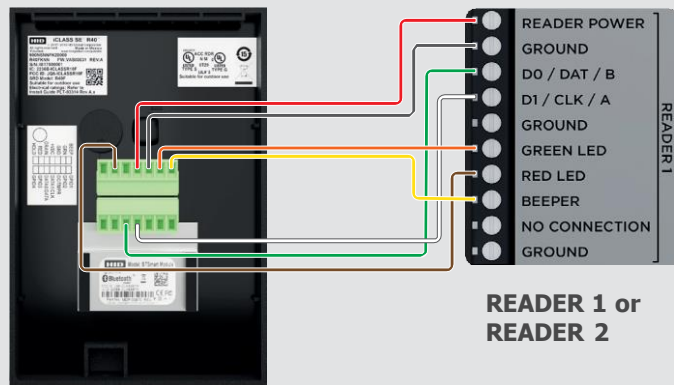

5. Relay circuit wiring

Four relays are provided for controlling door lock mechanisms or alarm signaling.

When controlling the delivery of power to the door strike, the **NO** (Normally Open) and **C** (Common) poles are typically used.

When momentarily removing power to unlock the door, as with a mag lock, the **NC** (Normally Closed) and **C** (Common) poles are typically used.

Check with local building codes for proper egress door installation.

CAUTION

Door lock mechanisms can generate feedback to the relay circuit. This can cause damage and premature failure of the relay, effecting the operation of the X1100. Use a diode to protect the relay. Use a wire of sufficient gauge to avoid voltage loss.

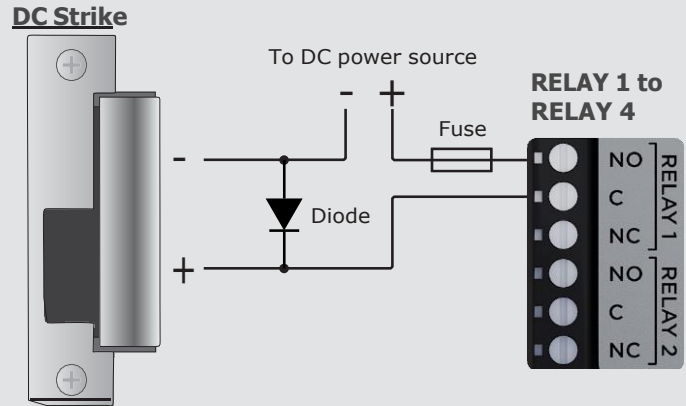

Diode selection:

- Diode current rating: 1x strike current.
- Diode breakdown voltage: 4x strike voltage.
- For 12 V DC or 24 V DC strike, diode 1N4002 (100V/1A) typical.

6. DIP switch configuration

The four DIP switches are used to configure the operating mode of the X1100 processor. DIP switches are read on power-up except where noted.

Press **RESET** switch to reboot the X1100.



1	2	3	4	DEFINITIONS
OFF	OFF	OFF	OFF	Normal operating mode.
ON	X	OFF	OFF	After initialization, enable default User Name (admin) and Password (password). The switch is read on the fly, no need to re-boot. For additional information, <i>See page 5</i> .
OFF	ON	OFF	OFF	Use factory default communication parameters.
ON	ON	OFF	OFF	Bulk Erase prompt mode at power up. <i>See page 5</i> .

Note: All other switch settings are unassigned and are reserved for future use. X = don't care.

Note: In the factory default modes, the downloaded configuration/database is not saved to flash memory.

Factory default communication parameters

- Network: static IP address: 192.168.0.251
- Subnet Mask: 255.255.0.0
- Default Gateway: 192.168.0.1
- DNS Server: 192.168.0.1
- Primary Host port: IP server, Data Security: TLS if Available, port 3001, communication address: 0
- Alternate Host Port: Disabled

7. Input circuit wiring

Inputs are typically used for the following:

- To monitor door position.
- Request to exit.
- Alarm contacts.

Input **IN 1** to **IN 4** circuits can be configured as unsupervised or supervised and can use normally open or normally closed contacts.

For a supervised circuit, add two 1K Ω , 1% resistors as close to the sensor as possible.

Custom end of line (EOL) resistances may be configured via the host software.

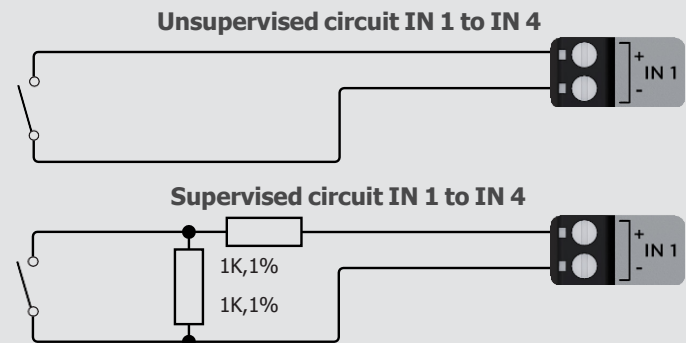

Note: The input circuit wiring configurations shown are supported but may not be typical.

8. Input power, cabinet tamper, and UPS fault input wiring

The X1100 requires 12-24 V DC power. Connect power with minimum of 18 AWG wire.

Connect the power ground to earth ground in only ONE LOCATION within the system. Multiple earth ground connections may cause ground loop problems and is not advised.

Observe POLARITY on 12-24 V DC input.

Connect the **AC FAIL** and **BATT FAIL** inputs to the corresponding contacts provided on the power supply. Connect the **TAMPER** input to a tamper switch on the enclosure.

TAMPER, AC FAIL, and BATT FAIL connections are identical to inputs **IN 1** to **IN 4** and can be configured as unsupervised or supervised. See step 7. *Input circuit wiring.*

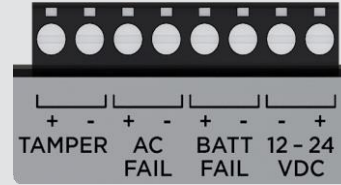

Bulk erase configuration memory

The bulk erase function can be used for the following:

- Erase all configuration and cardholder database (sanitize board, less third party applications).
- Recover from database corruption causing X1100 board to continuously reboot.

Note: If clearing the memory does not correct the initialization problem, contact technical support.

Bulk erase steps

1. Set DIP switches 1 and 2 to ON, and 3 and 4 to OFF.
2. Apply power to the X1100 board.
3. LED **ONLINE** is on for about 15 seconds while the X1100 boots up.
4. Change DIP switches 1 or 2 to OFF within 10 seconds, after LEDs **ONLINE** and **HOST COMM** and LEDs **IO INTERNAL** and **IO PORT 1** start flashing alternately at a rate of 0.5 seconds.
 - Note:** If these switches are not changed, the X1100 board will power up using the OEM default communication parameters.
5. LED **HOST COMM** will flash, indicating that the configuration memory is being erased.
 - Note:** Full memory erase takes up to 60 seconds.
6. When complete, only LEDs **ONLINE** and **IO PORT 1** will flash for about 3 seconds.
7. The X1100 board will complete its initialization two seconds after LEDs **ONLINE** & **IO PORT 1** stop flashing.

CAUTION: Do not remove power during the bulk erase process.

IT security

Ensure that the X1100 is installed securely. Create user accounts to the web configuration page using secure passwords.

Ensure that all DIP switches are in the OFF position for the normal operating mode.

After powering up the X1100 and connecting Ethernet, connect to the X1100 configuration manager by opening a browser and connecting to 192.168.0.251.

The X1100 is shipped with a default login account, which is enabled when DIP 1 is moved from OFF to ON (See step 6. *DIP switch configuration*). The default login User Name (admin) and Password (password) will be available for five minutes once the DIP switch is toggled. It is therefore important that at least one user account is defined, and the DIP switches are set to OFF before the X1100 is commissioned.

Configuring the X1100 with an IP address that is accessible from the public Internet is **not** recommended.

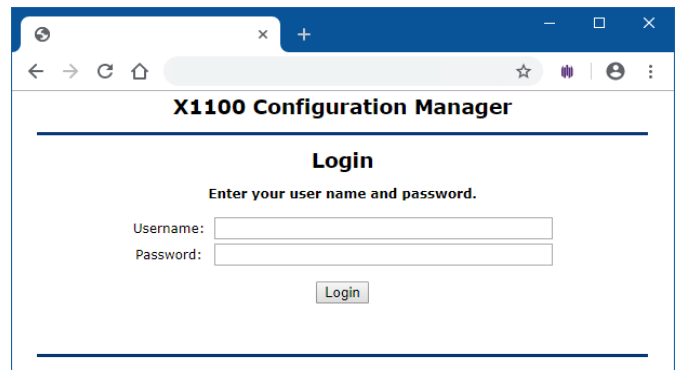

The following options are available to improve network security:

- Disable SNMP.
- Disable Zeroconf discovery.
- Disable the web configuration module.
- Enable data encryption over the host communication port.

Status LEDs

LED	POWER ON SELF-TEST	NORMAL OPERATION
BATT FAIL	On then OFF	OFF = Inactive, ON = Active, Flash = Fault.*
AC FAIL	On then OFF	OFF = Inactive, ON = Active, Flash = Fault.*
TAMPER	On then OFF	OFF = Inactive, ON = Active, Flash = Fault.*
IN 1	On then OFF	OFF = Inactive, ON = Active, Flash = Fault.*
IN 2	On then OFF	OFF = Inactive, ON = Active, Flash = Fault.*
IN 3	On then OFF	OFF = Inactive, ON = Active, Flash = Fault.*
IN 4	On then OFF	OFF = Inactive, ON = Active, Flash = Fault.*
ONLINE	ON for approximately 15 seconds	Off-Line / On-Line and battery status. On-Line = A long flash ON and a short flash OFF. Off-Line = A short flash ON and a long flash OFF. Double flash if battery is low.
HOST COMM	ON for approximately 1 second	Host communication activity (Ethernet).
IO INTERNAL	ON for approximately 1 second	Internal IO module communication activity.
IO MODULE PORT 1	ON for approximately 1 second	External IO module activity (Port 1).
IO MODULE PORT 2	ON for approximately 1 second	External IO module activity (Port 2).
READER 1	ON for approximately 1 second	OSDP Mode = Flashes when transmitting data. Wiegand or C&D Mode = Flashes when data is received, either input.
READER 2	ON for approximately 1 second	OSDP Mode = Flashes when transmitting data. Wiegand or C&D Mode = Flashes when data is received, either input.
RELAY 1	OFF	ON = Energized.
RELAY 2	OFF	ON = Energized.
RELAY 3	OFF	ON = Energized.
RELAY 4	OFF	ON = Energized.
ETHERNET	OFF	ETHERNET LED on Cover: Flashing = Ethernet activity ETHERNET JACK: Green/Left ON = good link Yellow/Right is ON = 100 Mb/s and OFF = 10 Mb/s

*If this input is defined, every three seconds the LED is pulsed to its opposite state for 0.1 seconds, otherwise, the LED is OFF.

Specifications

AERO X1100	
Input Voltage	12 to 24 V DC ±10%
Maximum Input Current	1.9 A (550 mA excluding readers and USB)
Micro USB Port	5 V DC, 500 mA maximum (reserved for future use)
Memory and Clock Backup Battery	3 Volt Lithium, type CR2032
microSD Card	Format: microSD or microSDHC; 2GB to 8GB (reserved for future use)
Host Communication	Ethernet: 10Base T/100Base-TX Micro-USB port (2.0)
IO Modules	Two independent ports: 2-wire RS-485, 2,400 to 115,200 bps, asynchronous, half-duplex, 1 start bit, 8 data bits, and 1 stop bit
Inputs	Seven unsupervised/supervised, standard EOL: 1k/1kΩ, 1%, ¼ watt (Includes TAMPER, AC FAIL, and BATT FAIL inputs) UL evaluation for access control use only
Output	Four relays, Form-C with dry contacts: Normally open contact (NO): 5 A @ 30 V DC resistive Normally closed contact (NC): 3 A @ 30 V DC resistive
READER INTERFACE	
Power	12 V DC ±10%, 500 mA maximum each reader
Data Inputs	TTL compatible or 2-wire RS-485
OSDP (RS-485) Mode	9,600 to 230,400 bps, asynchronous, half-duplex, 1 start bit, 8 data bits, and 1 stop bit. Maximum cable length: 2000 ft. (609.6 m)
LED Output	Open collector, 12 V DC open circuit maximum, 40 mA sink maximum
Beeper Output	
ENVIRONMENTAL	
Operating Temperature	32 to 158°F (0 to +70°C)
Storage Temperature	-67 to 185°F (-55 to +85°C)
Humidity	5 to 85% RHNC
MECHANICAL	
Dimension	6.46" × 5.51" × 1.02" (164 mm × 140 mm × 26 mm)
Weight	352 g

